

heften und
außen verschleifen

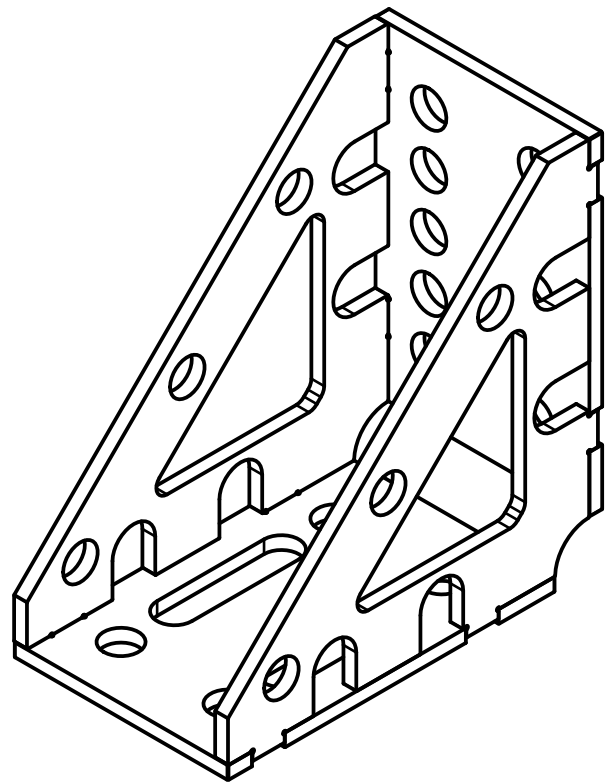

Stückliste

Pos.	Stk.	Artikelnummer	Bezeichnung	Gewicht	Werkstoff
1	1	NT-SM-0071	SW Langloch 2er	0,57 kg	1.0037 S235JR
2	1	NT-SM-0072	SW Bohrung 2er	0,61 kg	1.0037 S235JR
3	2	NT-SM-0013	SW Strebe	0,53 kg	1.0037 S235JR

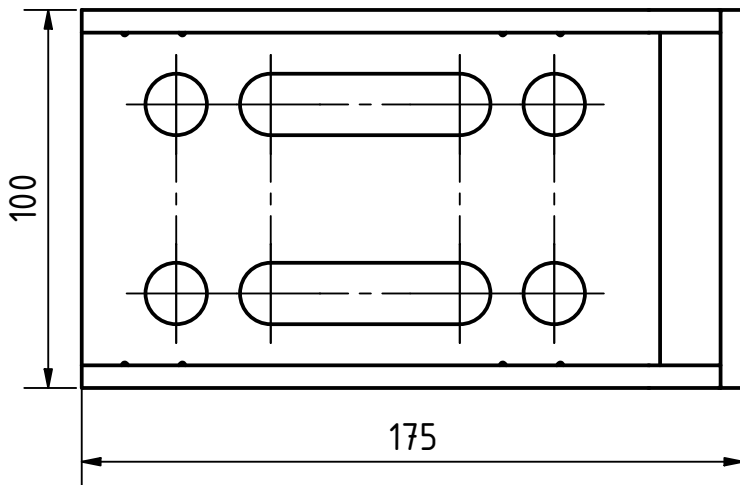

GERMANWELDINGTOOLS

Maße ohne Toleranzangabe
ISO 2768-mk

1 : 2

2,233 kg

bernhard

1.0037 S235JR

25.10.2019

Spannwinkel 2 Reihen

1 / 1

A4

NT-SM-0070